

# Product data sheet

Specifications



## variable speed drive ATV32 - 2.2 kw - 200 V - 1 phase - with heat sink

ATV32HU22M2

⚠ Discontinued on: Jan 23, 2021

⚠ Discontinued

### Main

Range of Product	Altivar 32
Product or Component Type	Variable speed drive
product destination	Synchronous motors Asynchronous motors
Product Specific Application	Complex machines
Function Available	-
Assembly style	With heat sink
Component name	ATV32
EMC filter	Class C2 EMC filter integrated
Phase	1 phase
[Us] rated supply voltage	200...240 V - 15...10 %
Supply voltage limits	170...264 V
Supply frequency	50...60 Hz - 5...5 %
Network Frequency	47.5...63 Hz
Motor power kW	2.2 kW 200...240 V
Maximum Horse Power Rating	3 hp 200...240 V

### Complementary

Line current	20.1 A 240 V 1 phase 2.2 kW / 3 hp 23.9 A 200 V 1 phase 2.2 kW / 3 hp
Apparent power	4.8 kVA 240 V 1 phase 2.2 kW / 3 hp
Prospective line I <sub>sc</sub>	1 kA 1 phase
Nominal output current	11 A 4 kHz 240 V 2.2 kW / 3 hp
Maximum transient current	16.5 A 60 s 2.2 kW / 3 hp
Output frequency	0.0005...0.599 kHz
Nominal switching frequency	4 kHz
Switching frequency	2...16 kHz adjustable
Speed range	1...100 asynchronous motor in open-loop mode
Speed accuracy	+/- 10 % of nominal slip 0.2 T <sub>n</sub> to T <sub>n</sub>
Torque accuracy	+/- 15 %
Transient overtorque	170...200 %

Price is "List Price" and may be subject to a trade discount – check with your local distributor or retailer for actual price.

<b>Braking torque</b>	<= 170 % with braking resistor
<b>Asynchronous motor control profile</b>	Voltage/frequency ratio, 5 points Voltage/frequency ratio - Energy Saving, quadratic U/f Flux vector control without sensor - Energy Saving, NoLoad law Flux vector control without sensor, standard Voltage/frequency ratio, 2 points
<b>Synchronous motor control profile</b>	Vector control without sensor
<b>Regulation loop</b>	Adjustable PID regulator
<b>Motor slip compensation</b>	Automatic whatever the load Not available in voltage/frequency ratio (2 or 5 points) Adjustable 0...300 %
<b>Local signalling</b>	1 LED red drive voltage 1 LED green CANopen run 1 LED red CANopen error 1 LED red drive fault
<b>Output voltage</b>	<= power supply voltage
<b>Noise level</b>	43 dB 86/188/EEC
<b>Insulation</b>	Electrical between power and control
<b>Electrical connection</b>	Screw terminal 4 mm <sup>2</sup> , AWG 10 power supply) Screw terminal 0.5...1.5 mm <sup>2</sup> , AWG 18...AWG 14 control) Removable screw terminals 1.5...2.5 mm <sup>2</sup> , AWG 14...AWG 12 motor/braking resistor)
<b>Tightening torque</b>	4.4 lbf.in (0.5 N.m), 4.4 lb/ft control) 6.2 lbf.in (0.7 N.m), 7.1 lb/ft motor/braking resistor) 5.3 lbf.in (0.6 N.m), 5.3 lb/ft power supply)
<b>Supply</b>	Internal supply for reference potentiometer (1 to 10 kOhm) 10.5 V DC +/- 5 %, <10 mA overload and short-circuit protection
<b>Analogue input number</b>	3
<b>Analogue input type</b>	AI1 voltage 0...10 V DC 30000 Ohm 10 bits AI2 bipolar differential voltage +/- 10 V DC 30000 Ohm 10 bits AI3 current 0...20 mA (or 4-20 mA, x-20 mA, 20-x mA or other patterns by configuration) 250 Ohm 10 bits
<b>Sampling duration</b>	2 ms AI1, AI2, AI3) - analog 2 ms AO1) - analog
<b>Response time</b>	LI1...LI6 8 ms +/- 0.7 ms logic R1A, R1B, R1C 2 ms relay R2A, R2C 2 ms relay
<b>Accuracy</b>	+/- 0.2 % AI1, AI2, AI3) for a temperature of -10...60 °C +/- 0.5 % AI1, AI2, AI3) for a temperature of 25 °C +/- 1 % AO1) for a temperature of 25 °C +/- 2 % AO1) for a temperature of -10...60 °C
<b>Linearity error</b>	+/- 0.2...0.5 % of maximum value AI1, AI2, AI3) +/- 0.3 % AO1)
<b>Analogue output number</b>	1
<b>Analogue output type</b>	AO1 software-configurable current 0...20 mA 800 Ohm 10 bits AO1 software-configurable voltage 0...10 V 470 Ohm 10 bits
<b>Discrete output number</b>	3
<b>Discrete output type</b>	Configurable relay logic R1A, R1B, R1C) NO/NC - 100000 cycles Configurable relay logic R2A, R2B) NO - 100000 cycles Logic LO)
<b>Minimum switching current</b>	5 mA 24 V DC configurable relay logic
<b>Maximum switching current</b>	R1 3 A 250 V AC resistive, cos phi = 1 R1 4 A 30 V DC resistive, cos phi = 1 R1, R2 2 A 250 V AC inductive, cos phi = 0.4 R1, R2 2 A 30 V DC inductive, cos phi = 0.4 R2 5 A 250 V AC resistive, cos phi = 1 R2 5 A 30 V DC resistive, cos phi = 1

<b>Discrete input number</b>	7
<b>Discrete input type</b>	Programmable (sink/source) LI1...LI4)24...30 V DC level 1 PLC Programmable as pulse input 20 kpps LI5)24...30 V DC level 1 PLC Switch-configurable PTC probe LI6)24...30 V DC Safe torque off STO)24...30 V DC - 1500 Ohm
<b>Discrete input logic</b>	Negative logic (sink) LI1...LI6), > 19 V, < 13 V Positive logic (source) LI1...LI6), < 5 V, > 11 V
<b>Acceleration and deceleration ramps</b>	U Ramp switching Deceleration ramp automatic stop DC injection S CUS Deceleration ramp adaptation Linear
<b>Braking to standstill</b>	By DC injection
<b>Protection type</b>	Input phase breaks drive Overcurrent between output phases and earth drive Overheating protection drive Short-circuit between motor phases drive Thermal protection drive
<b>Communication Port Protocol</b>	Modbus CANopen
<b>Connector type</b>	1 RJ45 on front face)Modbus/CANopen
<b>Physical interface</b>	2-wire RS 485 Modbus
<b>Transmission frame</b>	RTU Modbus
<b>Type of polarization</b>	No impedance Modbus
<b>Number of addresses</b>	1...127 CANopen 1...247 Modbus
<b>Method of access</b>	Slave CANopen
<b>Electromagnetic compatibility</b>	1.2/50 $\mu$ s - 8/20 $\mu$ s surge immunity test, level 3 IEC 61000-4-5 Conducted radio-frequency immunity test, level 3 IEC 61000-4-6 Electrical fast transient/burst immunity test, level 4 IEC 61000-4-4 Electrostatic discharge immunity test, level 3 IEC 61000-4-2 Radiated radio-frequency electromagnetic field immunity test, level 3 IEC 61000-4-3 Voltage dips and interruptions immunity test IEC 61000-4-11
<b>Width</b>	2.4 in (60 mm)
<b>Height</b>	12.8 in (325 mm)
<b>Depth</b>	9.6 in (245 mm)
<b>Net Weight</b>	6.4 lb(US) (2.9 kg)
<b>Option card</b>	Communication card CANopen daisy chain Communication card CANopen open style Communication card DeviceNet Communication card EtherNet/IP Communication card Profibus DP V1

## Environment

<b>Standards</b>	EN/IEC 61800-3 EN 61800-3 environments 2 category C2 EN 55011 class A group 1 EN/IEC 61800-5-1 EN 61800-3 environments 1 category C2
<b>Product Certifications</b>	C-tick NOM 117 UL CSA GOST
<b>Marking</b>	CE

<b>Pollution degree</b>	2 EN/IEC 61800-5-1
<b>IP degree of protection</b>	IP20 EN/IEC 61800-5-1
<b>Vibration resistance</b>	1 gn 13...200 Hz) EN/IEC 60068-2-6 1.5 mm peak to peak 3...13 Hz) EN/IEC 60068-2-6
<b>Shock resistance</b>	15 gn 11 msEN/IEC 60068-2-27
<b>Relative humidity</b>	5...95 % without condensation IEC 60068-2-3 5...95 % without dripping water IEC 60068-2-3
<b>Ambient air temperature for operation</b>	14...122 °F (-10...50 °C) without derating 122...140 °F (50...60 °C) with derating factor
<b>Ambient Air Temperature for Storage</b>	-13...158 °F (-25...70 °C)
<b>Operating altitude</b>	<= 3280.84 ft (1000 m) without derating 3280.84...6561.68 ft (1000...2000 m) with current derating 1 % per 100 m
<b>Operating position</b>	Vertical +/- 10 degree

## Ordering and shipping details

<b>Category</b>	22152-ATV320/ATV312/ATV32 (.25 THRU 7.5HP)
<b>Discount Schedule</b>	CP4B
<b>GTIN</b>	00785901940258
<b>Returnability</b>	No
<b>Country of origin</b>	ID

## Contractual warranty

<b>Warranty</b>	18 months
-----------------	-----------



Mounting and Clearance

Mounting and Clearance

---

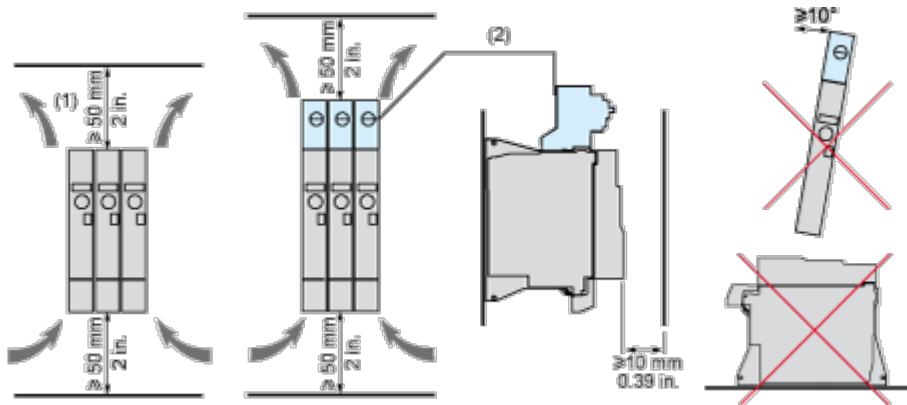

- (1) Minimum value corresponding to thermal constraints. A 150 mm clearance may help to connect the ground.
- (2) Optional GV2 circuit-breaker

**Option: Protection Device, GV2 circuit-breaker**

---

The drive is prepared to be equipped with an optional GV2 circuit-breaker. The GV2 circuit-breaker is directly mounted on the drive. Mechanical and electrical link are made using the optional adapter. The options are supplied with detailed mounting instruction sheet.

**NOTE:** The product overall dimension, including GV2 adapter and EMC plate mounted, becomes 424 mm (16.7 in.)

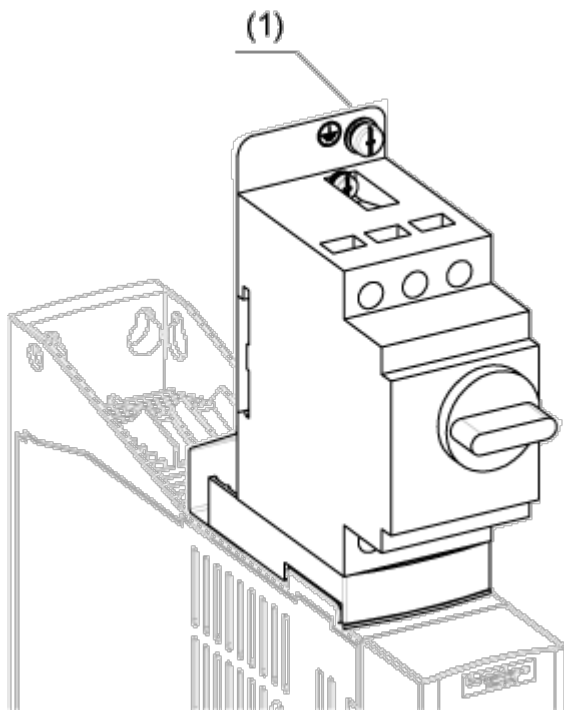

(1) Ground screw (HS type 2 - 5x12)

Connections and Schema

Connection Diagrams

Single or Three-phase Power Supply - Diagram with Line Contactor

Connection diagrams conforming to standards EN 954-1 category 1 and IEC/EN 61508 capacity SIL1, stopping category 0 in accordance with standard IEC/EN 60204-1.

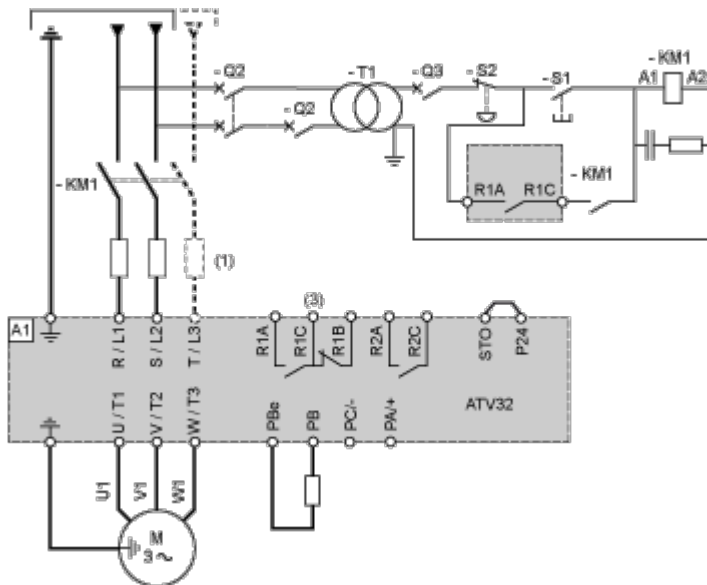

- (1) Line choke (if used)
- (3) Fault relay contacts, for remote signaling of drive status

Single or Three-phase Power Supply - Diagram with Switch Disconnect

Connection diagrams conforming to standards EN 954-1 category 1 and IEC/EN 61508 capacity SIL1, stopping category 0 in accordance with standard IEC/EN 60204-1.

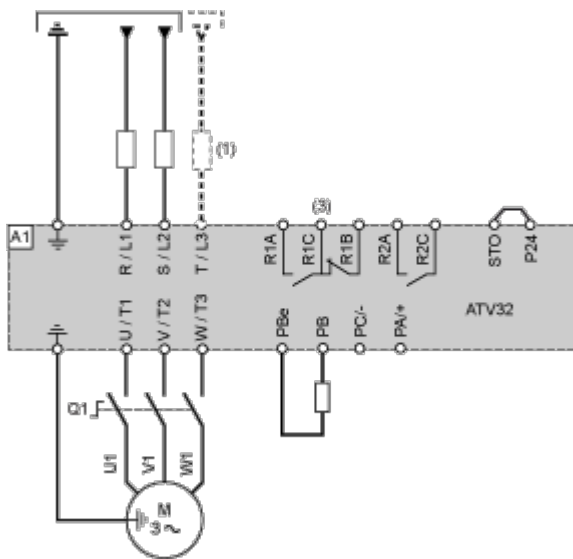

- (1) Line choke (if used)
- (3) Fault relay contacts, for remote signaling of drive status

Diagram with Preventa Safety Module (Safe Torque Off Function)



Connection diagrams conforming to standards EN 954-1 category 3 and IEC/EN 61508 capacity SIL2, stopping category 0 in accordance with standard IEC/EN 60204-1.

When the emergency stop is activated, the drive power supply is cut immediately and the motor stops in freewheel, according to category 0 of standard IEC/EN 60204-1.

A contact on the Preventa XPS AC module must be inserted in the brake control circuit to engage it safely when the STO (Safe Torque Off) safety function is activated.

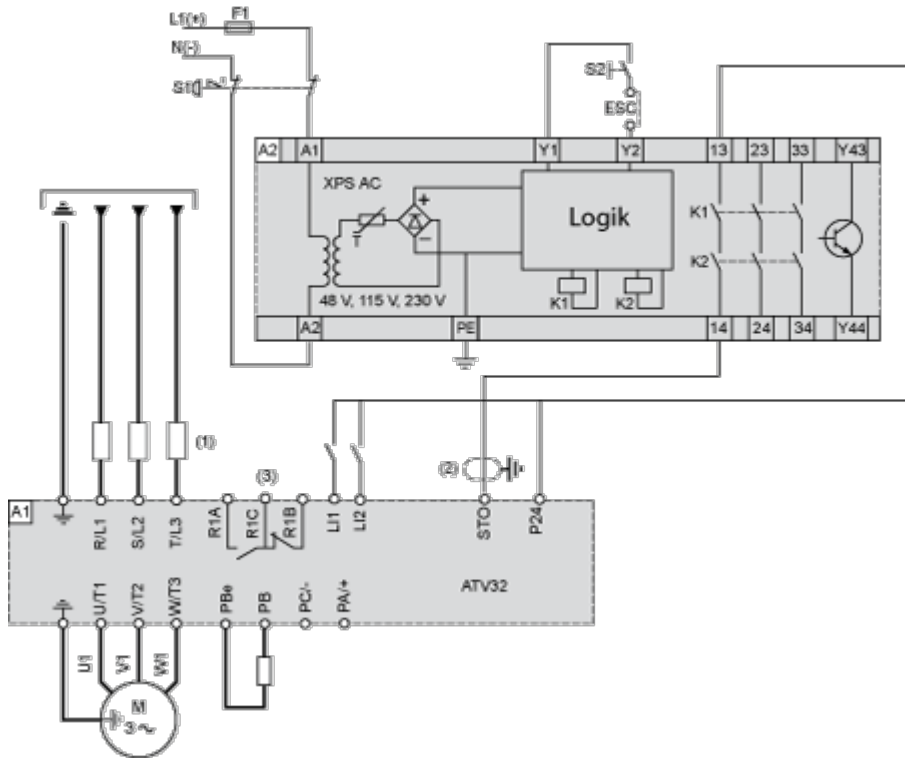

- (1) Line choke (if used)
- (2) It is essential to connect the shielding to the ground.
- (3) Fault relay contacts, for remote signaling of drive status

The STO safety function integrated into the product can be used to implement an "EMERGENCY STOP" (IEC 60204-1) for category 0 stops.

With an additional, approved EMERGENCY STOP module, it is also possible to implement category 1 stops.

**STO function**

The STO safety function is triggered via 2 redundant inputs. The circuits of the two inputs must be separate so that there are always two channels. The switching process must be simultaneous for both inputs (offset < 1 s).

The power stage is disabled and an error message is generated. The motor can no longer generate torque and coasts down without braking. A restart is possible after resetting the error message with a "Fault Reset".

The power stage is disabled and an error message is generated if only one of the two inputs is switched off or if the time offset is too great. This error message can only be reset by switching off the product.

**Diagram without Preventa Safety Module**

Connection diagrams conforming to standards EN 954-1 category 2 and IEC/EN 61508 capacity SIL1, stopping category 0 in accordance with standard IEC/EN 60204-1.

The connection diagram below is suitable for use with machines with a short freewheel stop time (machines with low inertia or high resistive torque).

When the emergency stop is activated, the drive power supply is cut immediately and the motor stops in freewheel, according to category 0 of standard IEC/EN 60204-1.

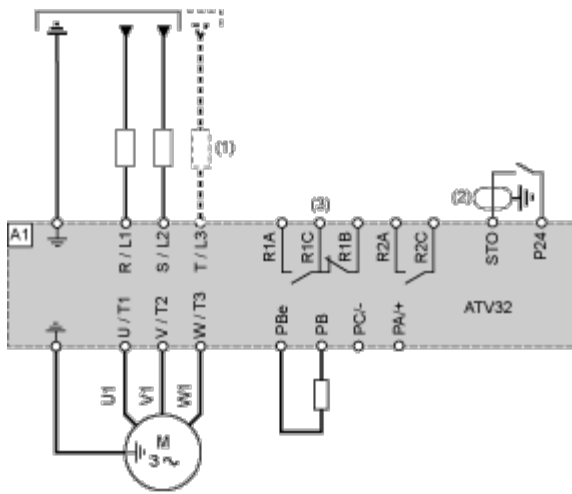

- (1) Line choke (if used)
- (2) It is essential to connect the shielding to the ground.
- (3) Fault relay contacts, for remote signaling of drive status

The STO safety function integrated into the product can be used to implement an "EMERGENCY STOP" (IEC 60204-1) for category 0 stops.

Control Connection Diagram in Source Mode

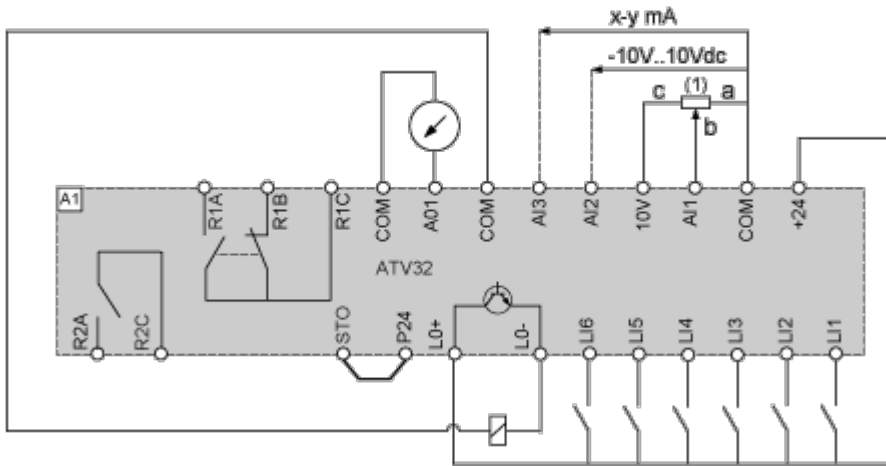

(1) Reference potentiometer SZ1RV1202 (2.2 kΩ) or similar (10 kΩ maximum)

Performance Curves

Derating Curves

---

Derating curve for the nominal drive current ( $I_n$ ) as a function of temperature and switching frequency.

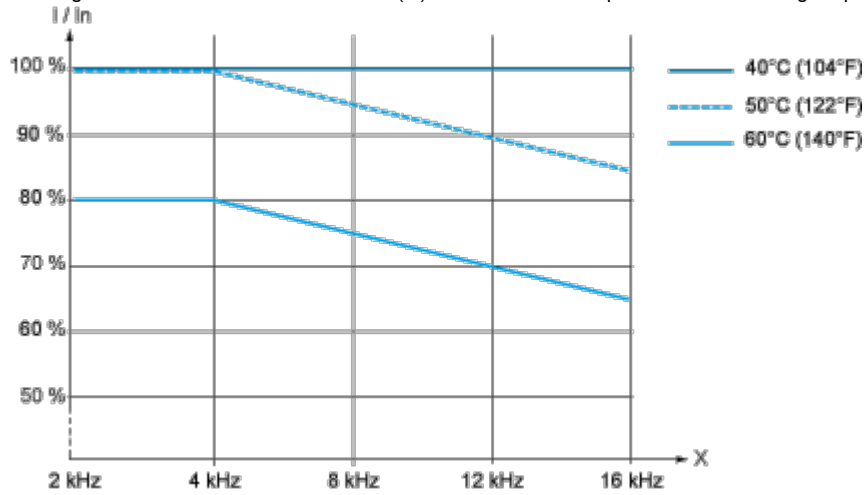

X Switching frequency

Above 4 kHz, the drive will reduce the switching frequency automatically in the event of an excessive temperature rise.

Technical Description

**Sink / Source Switch Configuration (SW1)**

The logic input switch (SW1) is used to adapt the operation of the logic inputs to the technology of the programmable controller outputs.

Switch SW1 set to "Source" position

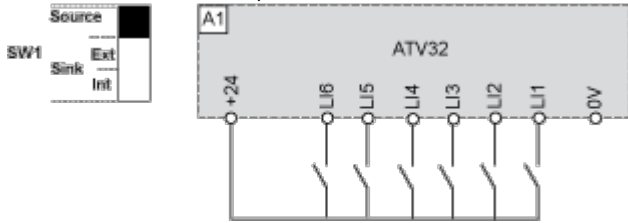

Switch SW1 set to "Source" position and use of an external power supply for the LIs

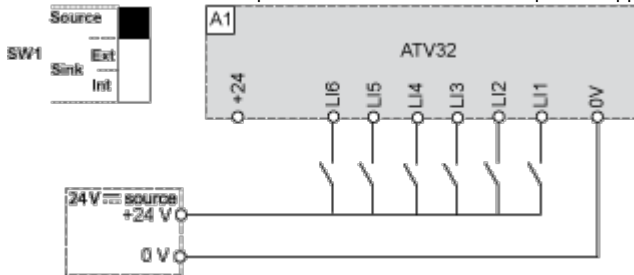

Switch SW1 set to "Sink Int" position

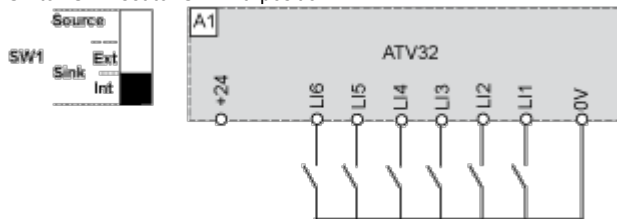

Switch SW1 set to "Sink Ext" position

